



EK-AV6 FREQUENCY DRIVE FOR HIGH VOLTAGE SYNCHRONOUS AND ASYNCHRONOUS ELECTRIC MOTORS WITH SQUARE-CAGE ROTOR

APPLICATION

EK-AV6-XX-XF-IX frequency drive (FD), produced by Energokomplekt LLC, is designed for providing effective speed control of medium voltage alternating current motors with stator voltage 3, 6, 10 kV. The FT is produced on power IGBT transistors with multilevel PWM. The EK-AV6-XX-XF-IX does not require installation of auxiliary equipment for reducing the negative consequences of energy transduction.

SYMBOLIC NOTATION STRUCTURE

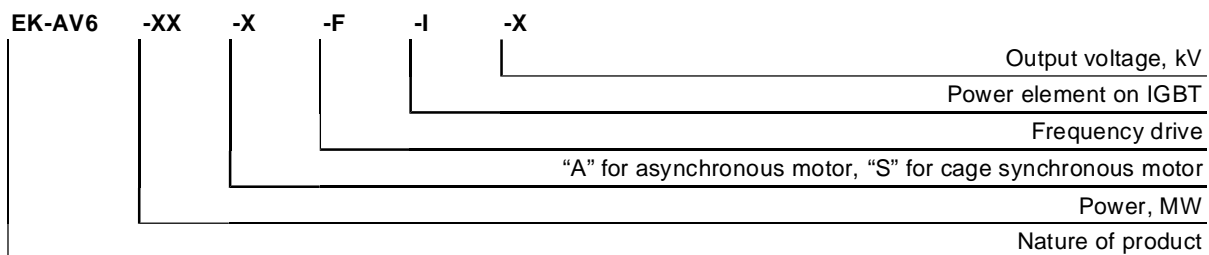

EK-AV6-XX-XF-IX is produced with all-digital control, can be applied in computer-aided manufacturing, operated and controlled with a top-level control system.



Fig. 1. EK-AV6-2.0-AF-I6 frequency drive, 2000 kW, 6 kV.

IF of the EK-AV6-XX-XF-IX has a powerful microprocessor-based control system, combined with quick-operating power modules, and thereby demonstrates the following advantages:

- | soft speed control in a broad range;
- | soft start and soft stop of the motor;
- | high accuracy of keeping up the process variable;
- | easy readjustment of the parameters for specific operational conditions;
- | significant reduce of the motor noise and vibration;
- | possibility of operation under top-level ACS control when using ModBus RTU, Profibus DP protocols.

When using EK-AV6-XX-XF-IX frequency drives:

- | there is no significant harmonic interference in supply mains;
- | power filters in IF chain are not needed;
- | cage induction motor;
- | length of cables from the IF to the motor can amount to 2 km;

- I coefficient of efficiency is not less than 0.97 by a frequency close to nominal;
- I dynamic braking of the motor (direct current supply to the stator) and running-out are possible;
- I selecting special motors with increased insulation class is not needed, the motor heating stays within normal limits;
- I it is possible to recover the IF operability in a short time without special instruments (a cell can be replaced in less than 30 minutes).

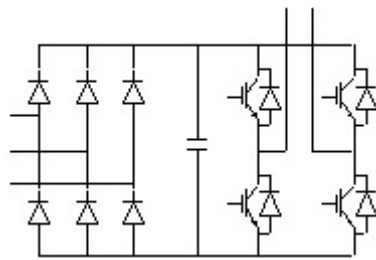

Fig. 2.????

OPERATING PRINCIPLE

For improving the quality of IF output voltage, the EK-AV6 contains a number of low-yield power width converters (cells). Each power cell has its own three-phase rectifier, connected to the input transformer secondary coil at the voltage 690 V. In the 6 kV IF, there are 15 cells of 690 V, connected in phase in series of 5, the phases are connected in a star. Each cell is designed for full output current, but operates for just 1/5 of the output voltage. Frequency drives for 3 and 10 kV contain respectively 3 and 8 cells in each phase.

STRUCTURE

Structurally the EK-AV6-XX-XF-IX consists of separate cabinets, each containing five power cells with forced air or water cooling. IF control system is installed in a separate control cabinet and is connected to the cells by a fiber-optic channel.

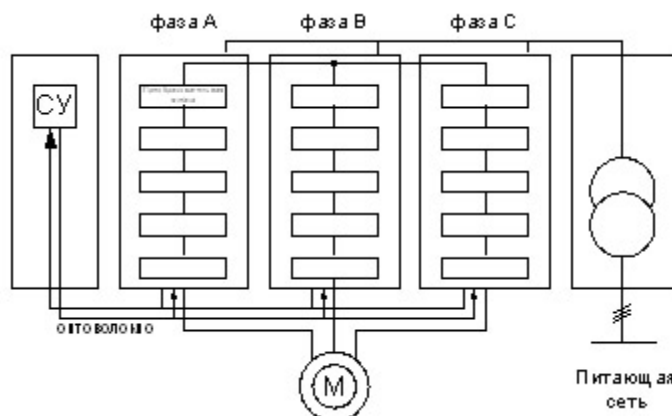

Fig. 3. Structural diagram of EK-AV6 series frequency drive.

The EK-AV6-XX-XF-IX has fully modular structure. A defective module can be easily and quickly replaced. A broken-down cell is automatically switched off without the operator interference, thereby the output power of the transmission falls by 10% (for IF, by 6 kV).

The power modules have improved reliability, for in the direct current chain there are polypropylene condensers in use with error-free running time 100,000 hours (10-12 years, while electrolytic condensers are designed for 5-7 years of operation). Each power cell has three temperature sensors outputting temperature information in real time scale and switching off any of them by exceed of operational temperature over the established value, and also optimizing the cooling system operation, thus elongating operational life of ventilators. In this way, any module can be excluded from the general sequence of phase voltage generation with a reduce of the transmission output by less than 10%. The information of currents, voltages, power generated by the cell and temperature data are transmitted by the module master controller via the fiber optic cable to the control cabinet. Each power module has all necessary shutdowns functioning independently of the primary FC control system, even by the fiber optic connection breakage.

The EK-AV6 control system is located in a separate cabinet; on the basis of signals received from power cells it realizes the motor control algorithm, power cells control algorithm (including equal power distribution) and necessary shutdowns of the power transformer and the FC as a whole. In the control cabinet, control signals for all IGBT keys of all the 15 power modules are formed simultaneously, and the information from each cell in the volume of over 120 signals simultaneously is processed. All the information in detail is output to the sensor panel, thereby there are no trimming resistors or capacitors in the control system, which improves its reliability.

The use of sensor panel allows significantly reducing the number of control elements in the control cabinet and making work with the device easier and clearer. The sensor panel allows multilevel access for field services and engineering staff, thus providing reliability in work and convenience in maintenance of the FC, that significantly reduces the requirements to maintenance staff qualification.

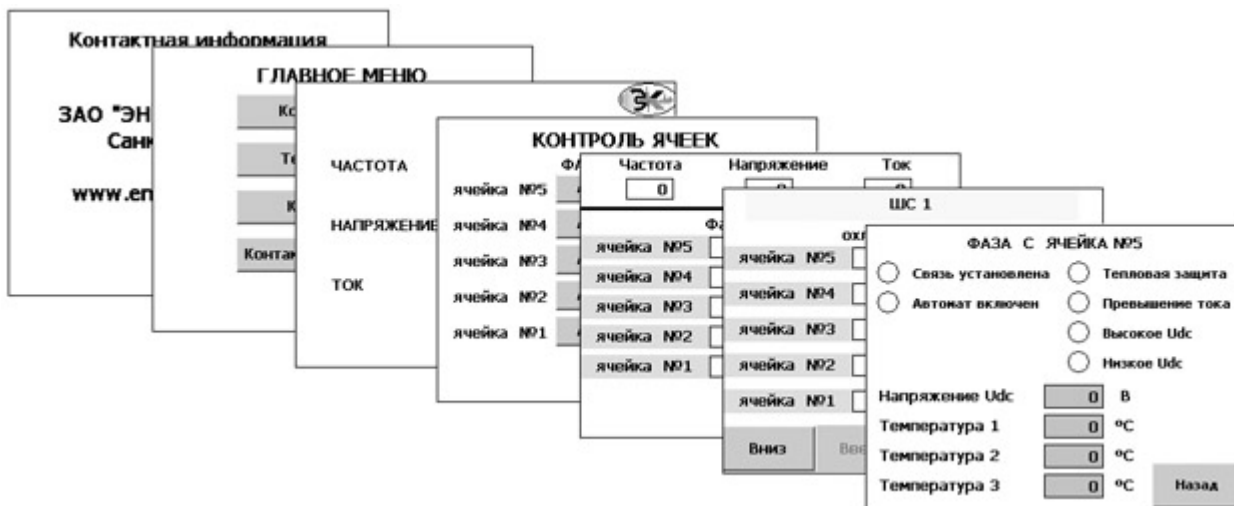

The sensor panel (6 inches) has an operator's menu for the 15 screens, by which one can easily access any EK-AV6 unit and obtain the values of characteristics in real time scale. The control system has a journal for 50 events, each of them fixing over 80 parameters of the system condition on the emergency moment (currents, voltages, active/reactive power, digital inputs/outputs position, coefficients values, etc.).

The use of a microprocessor-based control system with a sensor panel and fiber optic connection, and the use of low voltage power modules enables the manufacturing of high performance standards FC's, providing improved reliability and convenient maintenance.

The company supervises over equipment installation supervision, equipment alignment, provides for guaranty and post-guaranty service, maintenance staff training, technical advisory services on the equipment selection. The equipment is delivered within 6 months from the date of contract execution and prepayment.